

Gas Industry Standard

GIS/PRS/35: 2011

SPECIFICATION FOR

GRP HOUSINGS FOR GAS REGULATOR INSTALLATIONS AND ASSOCIATED OPERATION EQUIPMENT

Cadent
Your Gas Network

Northern
Gas Networks

 **SGN**
Your gas. Our network.

 **WALES&WEST**
UTILITIES

CONTENTS

| | |
|--|-----|
| CONTENTS | I |
| FOREWORD..... | III |
| MANDATORY AND NON-MANDATORY REQUIREMENTS | III |
| DISCLAIMER | III |
| BRIEF HISTORY..... | IV |
| KEY CHANGES | IV |
| SECTION 1 PRODUCT REQUIREMENTS | 1 |
| 1. SCOPE..... | 1 |
| 2. REFERENCES..... | 1 |
| 3. DEFINITIONS..... | 1 |
| 4. DESIGN | 2 |
| 5. SAFETY | 2 |
| 6. GENERAL INFORMATION..... | 3 |
| 7. LIFE OF HOUSING..... | 3 |
| 8. CONSTRUCTION..... | 3 |
| 8.13 Materials | 3 |
| 8.14 Bases and Fixing..... | 3 |
| 8.15 Walls..... | 4 |
| 8.16 Roof..... | 4 |
| 8.17 Doors | 5 |
| 8.18 Security..... | 6 |
| 8.19 Ventilators..... | 7 |
| 8.20 Notice Board | 7 |
| 8.21 Lifting | 8 |
| 8.22 Identification Plate | 9 |
| 8.23 Finish | 9 |
| 8.24 Provision for Gas Relief Vent Pipes | 9 |
| 8.25 Explosion Relief..... | 10 |
| 8.26 Instrument Panel Boards..... | 10 |
| 8.27 Safe-Area Compartment | 10 |
| 8.28 Sound Proofing..... | 11 |
| 9. PERFORMANCE REQUIREMENTS..... | 11 |
| 9.29 Ambient Temperature Range..... | 11 |
| 9.30 Fire Resistance | 11 |
| 9.31 Wind Loading | 12 |
| 9.32 Snow Loading..... | 12 |
| 10. ADDITIONAL PERFORMANCE TESTS..... | 12 |
| 10.33 General..... | 12 |
| 10.34 Soak Test..... | 12 |
| 10.35 Temperature Cycling Test..... | 13 |
| 10.36 Impact Testing..... | 13 |
| 10.37 Pass criteria Impact Test Appendix E.1 | 13 |

| | | |
|------------|--|----|
| 10.38 | Pass criteria Soft Body Impact Test Appendix E.2..... | 13 |
| | SECTION 2 QUALITY ASSURANCE REQUIREMENTS..... | 14 |
| 11. | SCOPE..... | 14 |
| 12. | RELATED DOCUMENTS..... | 14 |
| 13. | QUALITY MANAGEMENT SYSTEM..... | 14 |
| 14. | QUALITY PLAN..... | 14 |
| 14.42 | General..... | 14 |
| 14.43 | Purpose..... | 15 |
| 14.44 | Nominated contacts..... | 15 |
| 14.45 | Design control..... | 15 |
| 14.46 | Control of bought-in material..... | 15 |
| 14.47 | Control of parts manufacture..... | 15 |
| 14.48 | Control of sub-assembly..... | 15 |
| 14.49 | Control of product assembly and test..... | 15 |
| 14.50 | Inspection, measuring and test equipment..... | 16 |
| 14.51 | Product audit..... | 16 |
| 14.52 | Non-conforming product..... | 16 |
| 14.53 | Statistical techniques..... | 16 |
| 14.54 | Control of packaging and delivery..... | 16 |
| 14.55 | Product identification and traceability..... | 16 |
| 14.56 | Quality records..... | 16 |
| 14.57 | Control of spare parts..... | 16 |
| 15. | ACCESS FOR GIS DESIGNATED QUALITY ASSURANCE PERSONNEL..... | 17 |
| 16. | VALIDATION OF INITIAL PRODUCTION..... | 17 |
| 17. | CONCESSION AND PRODUCTION PERMIT PROCEDURE..... | 17 |
| APPENDIX A | REFERENCES..... | 18 |
| APPENDIX B | DEFINITIONS..... | 19 |
| APPENDIX C | (NORMATIVE) SOAK TEST..... | 20 |
| APPENDIX D | (NORMATIVE) TEMPERATURE CYCLING TEST..... | 21 |
| APPENDIX E | (NORMATIVE) IMPACT TESTS..... | 22 |
| APPENDIX F | LIST OF OPTIONS..... | 23 |

FOREWORD

GIS documents are revised, when necessary, by the issue of new editions. Users should ensure that they are in possession of the latest edition. Contractors and other users external to Gas Transporters (GT) should direct their requests for copies of a GIS to the department or group responsible for the initial issue of their contract documentation.

Comments and queries regarding the technical content of this document should be directed in the first instance to the contract department of the Gas Transporter (GT) responsible for the initial issue of their contract documentation.

This standard calls for the use of procedures that may be injurious to health if adequate precautions are not taken. It refers only to technical suitability and does not absolve the user from legal obligations relating to health and safety at any stage.

Compliance with this safety and engineering document does not confer immunity from prosecution for breach of statutory or other legal obligations.

MANDATORY AND NON-MANDATORY REQUIREMENTS

For the purposes of a GIS the following auxiliary verbs have the meanings indicated:

can: indicates a physical possibility

may: indicates an option that is not mandatory

shall: indicates a GIS requirement.

should: indicates best practice and is the preferred option. If an alternative method is used then a suitable and sufficient risk assessment shall be completed to show that the alternative method delivers the same, or better, level of protection.

DISCLAIMER

This engineering document is provided for use by Gas Transporters and such of their contractors as are obliged by the terms and conditions of their contracts to comply with this engineering document. Where this document is used by any other party it is the responsibility of that party to ensure that this engineering document is correctly applied.

BRIEF HISTORY

| | |
|---|-----------|
| Republished as GIS/PRS/35 from previous versions used by Gas Networks | Feb 2011 |
| Document Reviewed | Feb 2016 |
| Document Reviewed | July 2021 |

KEY CHANGES

| Document Review | Normative References Updated |
|-----------------|------------------------------|
| | |
| | |
| | |
| | |
| | |
| | |
| | |
| | |
| | |
| | |
| | |

SPECIFICATION FOR

GRP HOUSINGS FOR GAS REGULATOR INSTALLATIONS AND ASSOCIATED OPERATIONAL EQUIPMENT

SECTION 1 PRODUCT REQUIREMENTS

1. SCOPE

- 1.1 GIS/PRS/35 specifies the requirements for glass fibre reinforced plastic (GRP) housings for gas network regulator installations, and any associated operational plant.

Note: Housings for use with metering equipment are not covered by this document, and IGEM/GM8 should be used for these installations.

- 1.2 GIS/PRS/35 covers floor-mounted housings, with or without a base.
- 1.3 GIS/PRS/35 excludes housings for domestic meter installations, and housings for pit type installations.
- 1.4 Appendix F provide a list of options to be specified at the time of purchase and a typical order form.

2. REFERENCES

- 2.5 This Specification makes references to the documents listed in Appendix A. Unless otherwise specified, the latest edition of the documents apply, including all amendments.

3. DEFINITIONS

- 3.6 The definitions applying to this Specification are listed in Appendix B. Of particular importance are the following terms which describe the type of access required:

- **Non walk-in** - A housing for which maintenance is performed externally through the removal of panels or sections, and when the operative does not require access, see Figure 1a.
- **Walk-in (via one side)** - A housing for which maintenance is performed through access from one side of the installation only and with access on one side, see Figure 1b.
- **Walk-in (via two sides)** - A housing for which maintenance is performed through access from one or both sides of the installation but without direct passage from one side to the other, see Figure 1c.
- **Walk-in** – Applies to both ‘Walk-in (via one side)’ and ‘Walk-in (via two sides)’.
- **Walk-through** - A housing for which maintenance can be performed through access to all parts of the installation and with direct passage from one side to the other and access doors on both sides, see Figure 1d.

These terms dictate various requirements relating to the doors, height of roof, etc, and as such the purchaser needs to be clear about what is required.

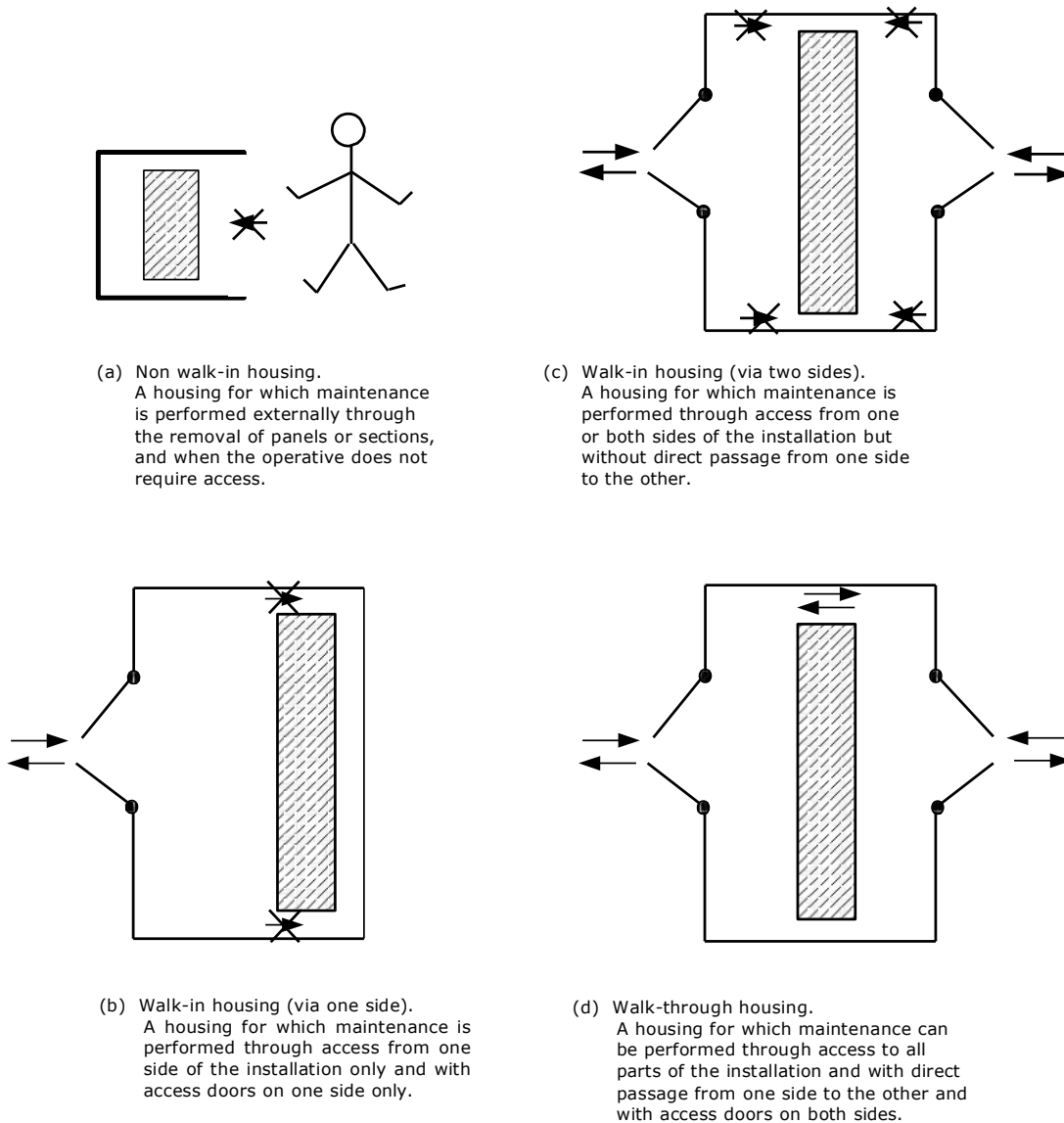

Figure 1 Types of access

4. DESIGN

Changes to the specification shall have prior agreement with the relevant Gas Transporter (GT). The notification of proposed changes shall be sent immediately to them for Approval. Full details will be required with a fully dimensioned engineering drawing, if appropriate, so that it can be determined if the modifications remain in accordance with the Gas Transporters requirements.

Note: *The purpose for requesting drawings and specifications is to enable the GT's designated quality assurance personnel to undertake objective and effective quality assurance. All information supplied will be treated in the strictest confidence, and will be covered by a confidentiality agreement (if required).*

5. SAFETY

5.7 The manufacturer shall ensure that all items supplied are safe and without risk to health when properly used by operators during handling, installation and during normal use.

6. GENERAL INFORMATION

- 6.8 Unless otherwise specified, all clauses apply to both resin bonded prefabricated sandwich construction housings and moulded housings.
- 6.9 Any opening in a housing should be restricted only to those for doors, ventilation, explosion relief, pipework and ancillary services.
- 6.10 Any 'walk-in' or 'walk-through' housing shall have a minimum internal height of 2.1 m.

7. LIFE OF HOUSING

- 7.11 Any housing, including fixing mechanisms, doors, etc. should be of maintenance free design, with the exception of door furniture when minor maintenance may be required.
- 7.12 Housings shall have a design life of at least 20 years.

8. CONSTRUCTION

8.13 Materials

- 8.13.1 The skin should be resin bonded. 'Walk-in' and 'Walk through' kiosks shall be of a sandwich construction which is cavity free. 'Non Walk-in' kiosks should be either a single skin or a sandwich construction which is cavity free.

Corners, door frames and base frames should be strengthened.

- 8.13.2 Any sandwich structure shall be formed from resin bonded glass fibre inner and outer skins totally encapsulating a suitable core material and shall meet the performance requirements of clauses 9.30, 9.31 and the additional performance tests in clause 10. The core material should be weather and boil proof marine plywood or weatherproof and boil proof hardwood (throughout) plywood, other material may be considered but will require written approval from the GT.
- 8.13.3 The wall outer or external skin shall meet the performance requirements of clauses 9.30, 9.31 and the additional performance tests in clause 10.
- 8.13.4 The thickness of the gel coat layers shall be in the range recommended by the gel coat manufacturers.
- 8.13.5 The GRP material shall fully encapsulate all edges and surfaces of any core material, and fixing methods that interrupt the continuity of the GRP surface shall be fully sealed to ensure that the ingress of moisture does not occur.
- 8.13.6 Where a framework is used, it should be of wooden or metal construction, suitably treated to prevent corrosion such that it will attain the design life specified in clause 7. The framework shall have a nominal cross section to adequately support the structure. All wooden joints shall be glued using appropriate timber adhesives and screwed, and all metal joints suitably welded to attain the design life specified in clause 7. The framework shall be totally encapsulated within the GRP structure.

Note: Other materials may be offered for consideration, provided they meet the performance requirements of clause 9 and the additional performance tests in clause 10.

- 8.13.7 Where metal items are manufactured from aluminium based light metals (e.g. door furniture, protection strips, etc) the magnesium content should not exceed 6% by weight.
- 8.13.8 Such items shall be protected against electrolytic action occurring where contact with steel is likely to occur.

8.14 Bases and Fixing

- 8.14.1 All base fixing points shall be inside the housing, to prevent unauthorised removal once installed.
- 8.14.2 The base flange shall be suitably reinforced and shall be provided with an appropriate number of fixing holes, which should be 16 mm diameter. Where an explosion relief roof has been specified the reinforcing should be metal or wood and shall be sufficient to withstand the effects of an explosion, see clause 8.25. The fixing holes shall be incorporated into the fabric of the base during construction. The pitch of the fixing holes shall not exceed 1000 mm.
- 8.14.3 The design and location of the fixing points shall ensure that accidental stress loading during installation is spread over the body of the housing, e.g. when tightening fixing bolts.
- 8.14.4 Sufficient M10 Rawl-type bolts and washers should be supplied by the housing manufacturer to utilise all fixing holes in the flange so that once installed the housing will meet the wind loading requirements in clause 9.31.

Note: *Larger bolts may be supplied if necessary.*

- 8.14.5 The GRP laminate on the underside of the base flange shall have a thickness of not less than 6mm and be suitably protected to prevent damage to its weather proofing in the event of the surface being abraded during installation of the housing.
- 8.14.6 Where the housing is designed to fit onto a concrete base, suitable non-setting sealant shall be provided sufficient to seal the base to the concrete standing. The sealing kit shall include fitting instructions and detail any safety precautions that may be required.

Note: *Lift-off housings may have an alternative means of base fixing, allowing for ease of removal without damaging the housing.*

- 8.14.7 In the case of 'Non walk-in' kiosks that are capable of being wall mounted, the base should incorporate two holes, one each side close to the back wall, (at least 40mm c/l hole) to allow bulkhead fitting and back nut.

8.15 Walls

- 8.15.1 Walls shall be designed as necessary to comply with the wind loading requirements in clause 9.31. Butt joints between adjacent sheets of core material, if utilised, shall not be aligned with corners or openings.
- 8.15.2 Where wall core material is fixed to the frame by means of a lap joint, the depth of the joint shall not be less than two thirds of the thickness of the frame.
- 8.15.3 Where housings are of sectional construction, the sections shall be fully formed, i.e. fully encapsulated. The joints shall be positioned to give maximum strength to the housing, and shall be suitably protected and sealed with non-setting sealant.
- 8.15.4 Walls shall not contain cavities.
- 8.15.5 Pipework shall not enter or exit the housing through the side walls unless the facility has been specifically provided and enabling removal of the housing, e.g. keyhole slots and infill panels.

8.16 Roof

- 8.16.1 The roof space shall not enclose any unventilated voids.
- 8.16.2 The roof shall be waterproof and shall project sufficiently over the walls to prevent water entering the ventilators. The roof shall have a minimum fall (gradient) of 1:60 in order to prevent water holding on the roof. Arrangements shall be made to allow rainwater to be shed away from the door access areas and safe area compartments.
- 8.16.3 The roof should be of lightweight construction and be strong the weight of persons walking on it (without duck boards), climbing, sitting or jumping on the kiosk.

Note: This requirement is in addition to the snow loading specified in clause 9.32.

- 8.16.4 On housings designated 'walk-in' and 'walk-through' the roof (or part of the roof) shall be capable of safe removal to facilitate maintenance of the installation.
- 8.16.5 The shape of the roof on a 'lift-off' housing shall not encourage anyone to stand or sit on the structure.
- 8.16.6 The roof shall withstand the wind and snow loading requirements in clauses 9.31 and 9.32.
- 8.16.7 In circumstances where the roof is not required to act as an explosion relief, it shall be securely attached to the walls, but see clause 8.16.4.
- 8.16.8 Where a design incorporates a hinged access roof, it should be fitted with stays to enable it to be held in the open position. The stays should be fitted in pairs and be capable of supporting the weight of the hinged roof while resisting any wind loading that may be applied to the hinged roof while in the open position.
- 8.17 **Doors**
- 8.17.1 Housings designated 'walk-in' or 'walk-through' shall have a double leaf outward opening door fitted to both walls designated length. The doors shall be capable of fully opening to approximately 180° and should be held back in that position, e.g. by a hook. In addition all doors should be fitted with a restraining device to secure the door open to 90° and be manually reset.
- 8.17.2 'Non walk-in' enclosures shall be provided with suitable means of access for maintenance and where appropriate meter reading, such access may be in the form of lift off panels, hinged roofs, doors or the housing may be designed to lift off as a unit.
- 8.17.3 Each door for 'walk-in' or 'walk-through' housings shall have a minimum nominal width of 800 mm and a minimum height of 2.0 m.
- 8.17.4 The doors shall be flush fitting, and be so designed to prevent any direct line of sight into the enclosure when the door is closed.
- 8.17.5 The doors should be constructed from GRP in moulded smooth or textured finish to a colour as specified in 8.23. Alternatively the doors can be constructed from treated hardwoods, if specified by the purchaser, see clause 8.17.7.
- 8.17.6 Doors shall be designed so that warping is minimised during weathering and minor deviations from square during installation will not cause the door to stick. The design shall ensure that rain water is prevented from entering.
- 8.17.7 Wooden doors shall be constructed from fully cured hardwood of 21 mm minimum thickness, conforming to BS 459 (wood) or an equivalent standard, and shall have an internal flame retardant barrier to meet the fire resistance requirements of clause 9.31. Where appropriate the barrier shall be protected against corrosion. Mild steel shall be painted with a phosphate-based primer, matching undercoat and two coats of gloss paint. Galvanized steel sheet may be left unpainted.
- 8.17.8 Doorsills on Walk-in/Walk-through kiosks shall be a maximum of 25 mm in height and be profiled to aid the passage of a pallet truck. They should be of corrosion resistant metal, and shall have a working life of at least 20 years.
- 8.17.9 Doorsills should be fitted with a 15 mm high weather strip giving a total height not exceeding 40 mm, which shall be removable, see Figure 2.
- 8.17.10 Internal and external door furniture shall be corrosion resistant and designed so that differential corrosion is minimized. Door locks, external handles, hinges and fixings should be 304 stainless steel.
- 8.17.11 Doors designated, as emergency exits shall be labelled as such.
-

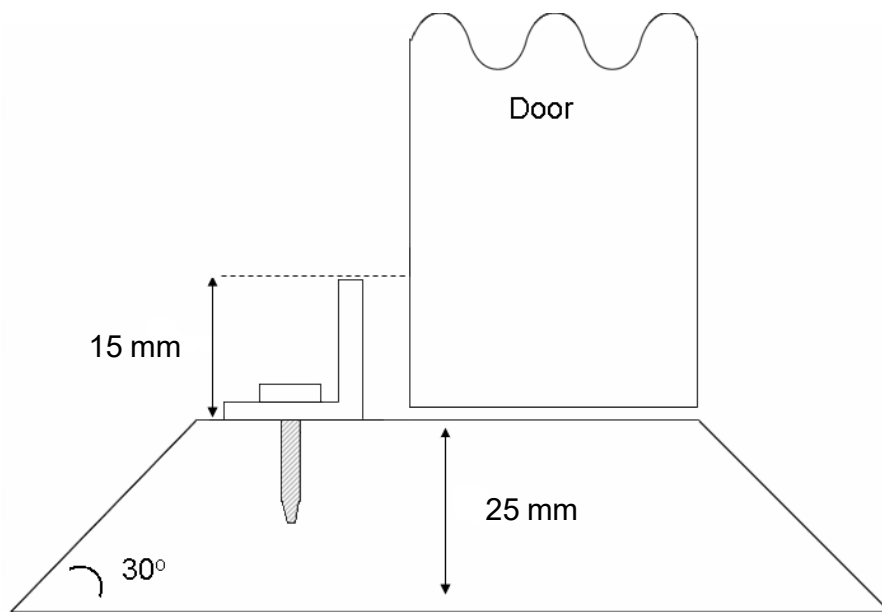

Figure 2 Door sill detail

8.18 Security

- 8.18.1 All means of access shall be secured against unauthorised entry.
- 8.18.2 Three hinges should be provided on doors 2.0 m or greater in height, located within 300 mm of top and bottom of the door and the other centrally. Alternatively, a continuous strip type hinge may be utilized. Housings with doors less than 2.0 m in height shall have at least two hinges.
- 8.18.3 The hinge design should ensure that any hinge securing bolts can only be removed from inside the housing or be totally concealed when the door is in the closed position.
- 8.18.4 The left hand door of the double doors designated 'front' shall be secured internally by two spring loaded shooting bolts capable of being locked in the open position, located top and bottom of the door and fixed vertically.
- 8.18.5 The right hand door or side doors of the double doors designated 'front' shall be secured by means of hasp and staple to accept a security lock with a diameter of 12 mm. The hasp should be positioned at the left hand edge of each right hand door when viewed externally and centrally located.
- 8.18.6 Rear access doors or side doors allowing access to the rear of the installation shall be secured to the equivalent standard as the front doors. In any 'walk through' housing that access shall be considered to be an 'Emergency Exit', see clause 8.18.9.
- 8.18.7 The double doors designated 'rear' on 'walk-in (via 2 sides)' housings should be secured in the same manner as the front.
- 8.18.8 Single doors on 'walk-in' housings shall be secured by means of hasp and staple to accept a security lock with a diameter of 12 mm or other agreed locking mechanism.
- 8.18.9 Rear doors or side doors used for "means of escape" in an emergency SHALL NOT be capable of being secured in such a way that they cannot be readily opened from within the housing in an emergency. Where an external key operated rear door locking facility is incorporated the doors should continue to be able to be opened from within the housing without the use of a key.

-
- 8.18.10 Shooting bolts and locking bars shall locate at the top and bottom of the doors either behind the door frame against keeper plates or within the suitable strengthened sill.
 - 8.18.11 Lift off panels and hinged roofs shall be secured by suitable locking mechanisms.
 - 8.18.12 Hinged access roofs shall have hold open stays that resist the wind loading requirements of clause 9.31.

8.19 Ventilators

- 8.19.1 The combined free area of the ventilation apertures shall be at least 3% of the floor area.

Note: A larger ventilation area may be requested by the purchaser as a special option.

- 8.19.2 The housing shall be ventilated directly to atmosphere by means of purpose-designed apertures.
- 8.19.3 Ventilators should be distributed as equally as possible between high and low level over the length of all four walls and should be positioned to provide effective ventilation of the entire enclosed space. The lower ventilation openings should be positioned approximately 150 mm above the floor. The upper ventilation openings should be situated as close as possible beneath, but not more than 10% of the total height below, the roof or ceiling level. Where housings have an apex type roof design, the high level ventilation should be achieved by utilising ridge ventilations.
- 8.19.4 Ventilators shall be of the non-adjustable type, shall be weatherproof and should be fire resistant.
- 8.19.5 Ventilators shall be designed to prevent the ingress of rain, and blockage by leaves or snow.
- 8.19.6 Any ventilator shall be designed and located to prevent persons tampering with the door restraining fixings.
- 8.19.7 The position of ventilators in 'walk-in' and 'walk through' housings' shall be such as to allow the optional inclusion of a safe-area compartment, see clause 8.27.
- 8.19.8 Any ventilator should be of a circular or square hole, or louver, design. The openings in any ventilator shall be such that a 9.5 mm diameter sphere cannot pass through, but shall be greater than 5 mm.
- 8.19.9 If ventilation is provided in the form of a gap(s) between the walls, doors, roof, etc of the housing, such a gap shall exceed 5 mm but not exceed 9.5 mm.

Note: The hazardous area from this type of ventilation may cause problems with the siting of electrical equipment.

- 8.19.10 Fly screens shall not be used.
- 8.19.11 All holes used for the fixing of ventilators shall be fully sealed and designed to ensure that the inner core material will not be exposed to moisture ingress.

8.20 Notice Board

- 8.20.1 A notice board shall be fitted to all 'walk-in' and 'walk-through' housings. The notice board should be fitted internally to the front wall of the housing, positioned to the right of the front door, as viewed from outside the intended main entrance.
 - 8.20.2 The notice board shall allow the use of drawing pins. The area of use of the notice board should be 600 mm by 420 mm.
 - 8.20.3 The method of fixing the notice board to the wall shall be such that the integrity of the GRP housing is not compromised.
-

8.21 Lifting

8.21.1 Any lift off housing/cover shall be capable of easy manhandling by no more than two people (one is preferred). The maximum height to which such a lift off housing/cover needs to be lifted to clear any components shall not exceed 1.8 m (see Figure 3).

Note: *The recommended maximum weight limit for 2 persons is 40 kg, and, for 1 person, 20 kg. However, this is subject to the method of lift. Advice is contained in the HSE Publication "Getting to grips with manual handling – a short guide".*

8.21.2 Where provided handles, (whether fixed or operational) should:

- a) be positioned for ease of access and operation, and
- b) be located so that personnel moving a housing/cover maintain a good posture and are not in danger of walking into equipment under the housing/cover, and .
- c) be positioned to balance the centre of gravity, and
- d) be designed to discourage their use by unauthorized persons e.g. by being incorporated discreetly into the shape of the housing.

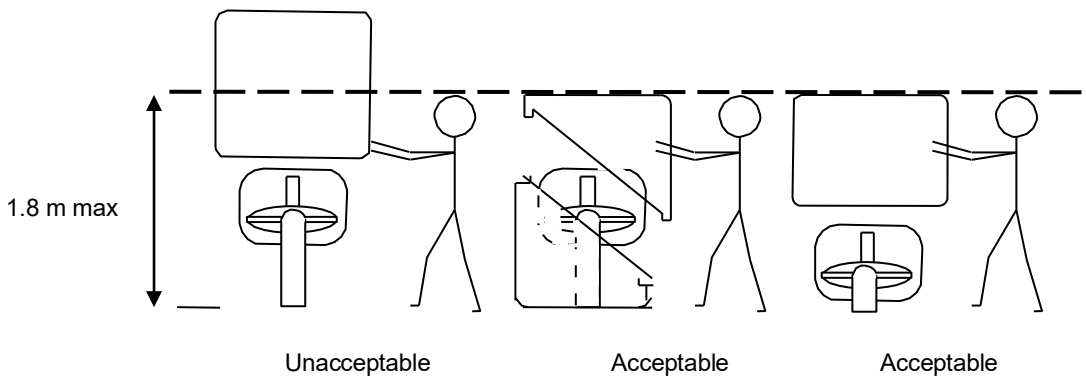

Figure 3 lift off housings/covers. Ease of Handling

8.21.3 Any pre-fabricated housing/cover or component of weight exceeding 40 kg that requires lifting either during construction or to facilitate maintenance, shall be fitted with an appropriate number of lifting eyes. Such lifting eyes shall be positioned to facilitate a safe and level lift of the housing/cover or component, in accordance with the Lifting Operations and Lifting Equipment Regulations.

Compliance should be verified by an independent body.

8.21.4 Where lifting eyes are fitted, sufficient plugs shall be provided to allow the permanent sealing of the holes following removal of the lifting eyes. The sealing method shall ensure that water ingress is permanently prevented.

8.21.5 The design of the lifting eyes shall be such that the operation of an explosion relief roof (where fitted), is not affected if they are not removed.

8.22 Identification Plate

- 8.22.1 Any pre-fabricated housing shall have an identification plate permanently and prominently fixed to the inside of the entrance door or panel, without compromising the housing integrity, giving the following information:
- a) The manufacturer and model number.
 - b) The date of manufacture.
 - c) The serial number/batch number.
 - d) The gross weight of the housing.
 - e) The roof/lift off panel weight (when removable).
 - f) A space for the order number to be written on prior to dispatch.
 - g) The text "GIS/PRS/35".
 - h) Fixing bolt tightening torque.
 - i) Actual ventilation area (high and low) and total ventilation as a % of floor area.
 - j) The location of ventilation e.g. soffit, or designed into door mounting, etc.

8.23 Finish

- 8.23.1 The housing external finish should be smooth or textured and should be of a colour BS 4800 green 14-C-39.
- 8.23.2 Alternatively, the purchaser may specify an alternative finish at the time of purchase, e.g. another colour, stone effect, brick effect, cement render effect.
- 8.23.3 The finish shall incorporate UV stabilization with the aim of achieving minimal degradation over a life of at least 20 years.
- 8.23.4 All colourings used within surface materials should not unduly fade due to the action of normal weather conditions experienced within Great Britain for at least 20 years.
- 8.23.5 The finish should allow the removal of graffiti (using appropriate materials specified by the manufacturer) without suffering any undue damage to the coating material.
- 8.23.6 The internal finish of 'walk in' and 'walk through' housings shall be white.

8.24 Provision for Gas Relief Vent Pipes

- 8.24.1 Where the kiosk is manufactured using a sandwich construction clearly identifiable panels, designed specifically for the exit of a vent pipe, should be provided. The panels shall consist of solid GRP with no core material, but with any decorative finish to match the rest of the housing.
- 8.24.2 For 'walk in' and 'walk through' kiosks a clearly defined relief vent panel of dimensions 700 mm long by 100 mm high should be incorporated into sandwich construction housings in both walls designated width, through which relief vent pipes may pass. The panels shall be located centrally in the horizontal plane of the wall, and shall not be in the immediate vicinity of the ventilation.
- 8.24.3 The option for the pre-drilling of up to six 40 mm nominal diameter holes in either or both panels shall be made available. The holes shall be at 100 mm intervals equidistant from the centre line of the wall.

In the case of small 'non walk in' kiosks a single 32 mm hole shall be drilled in the back of the box, and each side, not in the immediate vicinity of the ventilation, e.g. not within 100 mm.

These holes shall be plugged in such a manner that deters their removal from outside the housing. The sealed holes shall not allow water ingress into the housing.

8.25 **Explosion Relief**

8.25.1 Where specified by the purchaser, explosion relief shall conform to the following:

- The explosion relief shall be designed to limit the maximum internal pressure developed during an explosion to 35 mbar.
- An explosion relief would, normally, be provided by the roof of the housing lifting. However, where circumstances permit the use of an explosion panel within the roof, the discharge area shall not be less than 50% of the area of the roof. Alternatively, an explosion relief can be provided by the door or panel in an outside wall.
- The explosion relief shall be provided with restraining fixings which shall be contained within the housing and shall be designed to allow vertical movement but limit unwanted lateral movement.
- The restraining fixings of the roof / panel shall be designed such that the operation of the explosion relief will not damage any wall of the building.
- Following operation, the relief shall reseal in its original position.
- The housing shall be capable of withstanding the maximum internal pressure developed during an explosion and designed such that there shall not be any fragmentation to cause a hazard in the event of an explosion.
- The explosion relief shall be designed to prevent damage to equipment within the housing when it reseals to its original position following operation.
- To maintain the required degree of security, an explosion relief shall not provide easier means of access than a locked door.
- Doors and fittings shall be strong enough that where explosion relief is fitted, an explosion shall not cause the doors to open, the hinges shall remain in an operational condition, the doors should not unduly bow allowing flames, etc, to escape through the door. This may necessitate the fitting of a 3 point locking mechanism.

Compliance should be verified by an appropriate test method, physical test report, and photographic/video evidence.

8.26 **Instrument Panel Boards**

8.26.1 Provision shall be made for the fixing of optional instrument panel boards to the interior of 'walk in' and 'walk through' housings on each wall, designated width.

8.26.2 The overall size will be specified by the customer; however the panels shall be constructed of WBP exterior grade plywood, with a thickness of 18 mm or greater.

8.26.3 The method of fixing the panels to the interior walls shall be such that the integrity of the GRP housing shall not be compromised.

8.26.4 Instrument cable access points shall be provided near to the instrument panel to allow connection to equipment outside the housing without compromising the integrity of the structure.

8.27 **Safe-Area Compartment**

8.27.1 'walk in' and 'walk through' housings shall be specified by the purchaser to have either:

- a) Provision for attaching an instrument housing externally to the housing. The method of the fixing shall not compromise the integrity of either housing.

-
- b) A safe area compartment.
- 8.27.2 Pre-fabricated safe area compartments should be internally moulded/attached, projecting into the housing but completely sealed from it.
- Note:** *It shall be possible to mount logging and conversion equipment within the compartment such that it is totally isolated from the main housing.*
- 8.27.3 Access shall be through an external outward-opening door. The door shall be secured with a suitable lock and key, e.g. triangular gas key.
- 8.27.4 The following optional compartments will be possible, and shall have the following internal dimensions:
- Size A 450 mm x 300 mm x 600 mm (width, depth, height).
- Size B 900 mm x 300 mm x 600 mm (width, depth, height).
- 8.27.5 The design of the compartment shall be such that all cables shall be routed into the compartment externally of the main GRP housing without compromising the integrity of either.
- 8.27.6 All cables and glands shall be matched and should be to IP 65.
- Note:** *The number of glands is to be specified at the time of purchasing.*
- 8.27.7 The IP rating of the external door should be to IP65.
- 8.27.8 The safe-area compartment (or mounting points for an instrument house):
- a) should be located in a position that will not impede access to the installation, and
 - b) shall not be in the immediate vicinity of the ventilators, and
 - c) shall not be fitted to the same wall as the relief vent pipes.

8.28 Sound Proofing

Note: *Additional sound proofing of the housing may be required as an optional extra, the details of which will be specified by the purchaser at the time of purchase.*

9. PERFORMANCE REQUIREMENTS

9.29 Ambient Temperature Range

- 9.29.1 The housing shall suffer no defects due to temperature within the ambient temperature range -20 °C to +50 °C.

9.30 Fire Resistance

- 9.30.1 Materials used in the construction of the external surface shall have a fire performance in accordance with this section.
- 9.30.2 When tested to BS 476 Part 12, utilising flame 'Source G', 500mm x 750mm there shall be no holes formed in any of the tested specimens when the flame is applied for 3 minutes. The sample shall retain its physical strength which shall be demonstrated by compliance with the impact test specified in Appendix E.3. Following the test there shall be no holes formed in the panel.

9.30.3 When a large representative section of the housing (1000mm x 1000mm) is tested (in the vertical orientation) to BS 476 Part 12, utilising flame 'Source E' for a period of 20 minutes, the sample shall show:

- no signs of penetration, and
- the extent of damage shall be limited to an area no wider than 550 mm, and
- the flames shall self extinguish within 5 seconds of the 'source E' being extinguished.

Note 1: A kiosk approximately 1m x 0.54 m x 0.96 m, may be used as an alternative to a test panel.

Note 2: The flame source is to be positioned such that it is approximately 25 mm from the surface of the test panel, and impinges on the face of the test panel at an angle of 45 degrees at a point approximately 100 mm from the base of the panel.

9.31 Wind Loading

9.31.1 When installed in accordance with the manufacturer instructions the housing walls and roof shall withstand wind speeds of 50 m/s. Any explosion relief roof fitted shall operate correctly under the load conditions. Compliance should be verified either by design calculations or by an appropriate test method.

9.32 Snow Loading

9.32.1 The roof of the housing shall withstand a uniformly distributed load of 1.25 kN/m². Compliance should be verified either by design calculations or by an appropriate test method.

10. ADDITIONAL PERFORMANCE TESTS

10.33 General

10.33.1 Unless otherwise specified, tests shall be carried out at an ambient temperature of 20 °C ± 5 °C.

10.33.2 Pre-fabricated sandwich test specimen panels, to the proposed production standards for this design, being a panel 1.0 m square in area and shall have the core material exposed on all four edges.

10.33.3 The sequence of testing shall be as follows:

- a) Soak Test - Clause 10.34:
- b) Temperature - Cycling Test. Clause 10.35:
- c) Impact Testing - Clause 10.36.

10.34 Soak Test

10.34.1 The housing material shall be tested in accordance with Appendix C.

10.34.2 Following the test, the housing material shall not suffer any visible degradation of the material. This shall be interpreted to mean that expansion or swelling of the original thickness of the tested material shall not exceed 1.5mm at any of the test points and the average dimension change experienced at the 16 test points shall not exceed 0.5mm.

The test sample shall not increase in weight by more than 1900gm.

10.34.3 Evidence shall be submitted by appropriate physical test report and supporting photographs.

10.35 Temperature Cycling Test

- 10.35.1 The housing material shall be tested in accordance with Appendix D.
- 10.35.2 Following the test, the housing material shall not suffer any 'visible degradation' of the material. This shall be interpreted to mean that expansion or swelling of the original thickness of the tested material shall not exceed 1.5mm at any of the test points and the average dimension change experienced at the 16 test points shall not exceed 0.5mm.
- 10.35.3 Evidence shall be submitted either by an appropriate physical test report and supporting Photographs or an appropriate product design calculation.

10.36 Impact Testing

- 10.36.1 The housing material shall be tested in accordance with Appendix E. Following the tests the specimen panel shall meet the requirements of 10.37 and 10.38 and there shall be no evidence of damage likely to cause structural weakness.

10.37 Pass criteria Impact Test Appendix E.1

- 10.37.1 The housing material shall not suffer any "visible or measurable deformation" or cracking of the material.
- 10.37.2 Moulded housing material comprising of single skin GRP may suffer a starcrack of maximum crack length of 2 mm from the point of impact without de-lamination. The crack shall not penetrate more than 1 mm into the surface of the material.
- 10.37.3 Evidence shall be submitted by appropriate physical test report and supporting photographs.

10.38 Pass criteria Soft Body Impact Test Appendix E.2

- 10.38.1 The housing material shall not suffer any visible or measurable deformation or cracking of the material.
- 10.38.2 Evidence shall be submitted by an appropriate physical test report and supporting photographs.

SECTION 2 QUALITY ASSURANCE REQUIREMENTS**11. SCOPE**

11.39 This section specifies the minimum quality assurance requirements for products covered in Section 1 of this document.

12. RELATED DOCUMENTS

12.40 All drawing requirements shall be complied with and no alteration shall be made without the written consent of the GT.

13. QUALITY MANAGEMENT SYSTEM

13.41 A formalised quality management system is required. Either the supplier shall provide evidence of certification by an accredited independent third party certification body or where a supplier does not hold the aforementioned certification, the supplier's quality management system shall be subject to evaluation by quality assurance personnel. The requirements of BS EN ISO 9001, as appropriate, shall be used for this purpose. A copy of the supplier's quality manual, relevant quality plans and other related documents shall be provided on request.

14. QUALITY PLAN**14.42 General**

14.42.1 The supplier shall provide a quality plan that demonstrates to the designated quality assurance personnel that the items supplied conform to the requirements of this specification.

14.42.2 Any changes to the quality plan shall be agreed between the GT and the supplier before introduction.

Note 1: *Much of the generic documentation required will normally be contained in the supplier's existing quality manual and supporting procedures. The quality plan will provide a mechanism to tie existing generic quality system procedures to the specific requirements of this specification.*

Note 2: *The format of and the level of detail in the plan should suit the supplier's method of operation and the complexity of the activities to be performed. The plan should be as brief as possible and may be in the form of flow diagrams, a textual presentation or a mixture of both.*

Note 3: *The plan should indicate, either directly or by reference to appropriate procedures or other documents, how the required activities are to be carried out.*

14.42.3 Where applicable, the quality plan shall include, but is not limited to, the following elements:

- a) Purpose.
- b) Nominated contacts.
- c) Design control.
- d) Control of bought-in material.
- e) Control of parts manufacture.
- f) Control of sub-assembly.
- g) Control of product assembly and test.
- h) Inspection, measuring and test equipment.
- i) Product audit.
- j) Non-conforming product.
- k) Statistical techniques.

- l) Control of packaging and delivery.
- m) Product identification and traceability.
- n) Quality records.
- o) Control of spare parts.

Note: Requirements and guidance on the content of these elements follows below.

14.43 **Purpose**

- 14.43.1 The purpose of the quality plan shall define the Product Specification (and issue) to which it is to be applied.

14.44 **Nominated contacts**

- 14.44.1 Contact details of the supplier's personnel with responsibility for the following aspects shall be provided.
- a) Production quality. This concerns those matters, which arise during manufacture of the product and its associated component parts.
 - b) Technical quality. This relates to those matters arising from the design and performance of the product and its associated component parts.
 - c) Service quality. This relates to those matters, which arise in the field or on any products and their associated parts returned from the field.

14.45 **Design control**

- 14.45.1 The quality plan shall indicate when, how and by whom validation and verification of design output conformity to design inputs is to be carried out, controlled and documented. Where applicable, the plan shall indicate the extent to which the customer is to be involved in design activities, such as participation in design reviews and design verification tests. The plan shall reference applicable codes, standards and specifications.

14.46 **Control of bought-in material**

- 14.46.1 Details shall be provided of the actions to be taken to control the quality of bought-in material including raw materials. This shall also include manufactured parts or components, which are sent out to sub-contractors for further processing.

14.47 **Control of parts manufacture**

- 14.47.1 This shall describe the controls applied to all parts of the product, which are manufactured in house. This shall include bought-in items, which are subject to further manufacturing operations.
- 14.47.2 Where parts are subjected to subsequent processing, details shall be provided to show the controls applied to ensure conformity of process and product.

14.48 **Control of sub-assembly**

- 14.48.1 This shall detail any control operations carried out on sub-assemblies prior to their assembly into the product, but excluding any detailed previously.

14.49 **Control of product assembly and test**

- 14.49.1 The test and inspection procedures applied during and/or following product assembly shall be detailed. This shall include reference to all tests applied during routine examinations together with any additional checks carried out during first off examinations.
- 14.49.2 Any additional tests, type tests or inspections carried out on an occasional but predetermined basis to check particular attributes of the product or to prevent performance drift, shall be included.

14.50 Inspection, measuring and test equipment

- 14.50.1 The quality plan shall indicate the control system to be used for inspection, measuring and test equipment specifically intended for use for the product, including calibration and calibration status.

14.51 Product audit

- 14.51.1 Details shall be given of product audits carried out to determine whether production remains in control (see note 1).

***Note 1:** These details should indicate the extent of any tests and inspections performed detailing such aspects as responsibility, sample source, whether the product is complete and packaged, relevant acceptable quality levels (AQL's), audit sampling frequency etc. (see also notes 2, 3 and 4).*

***Note 2:** There is no AQL for critical non-conformances. A critical non-conformance is defined as one that will cause the product to be hazardous to the installer, user or environment.*

***Note 3:** Where any doubt arises in the use of sampling plans and/or the definitions of Class A and B characteristics, reference should be made to BS 6001: Part 1.*

***Note 4:** The AQL for Class A is 1.5% and the AQL for Class B is 2.5%. (General inspection level 1 - single sampling plan for normal inspection.)*

14.52 Non-conforming product

- 14.52.1 The quality plan shall indicate the procedures to be followed when a non-conforming product is found. This shall cover aspects such as the identification and segregation of affected products, sub-assemblies or other components and the implementation of corrective action.

- 14.52.2 The quality plan shall include a list of contacts who shall be informed when a non-conforming product is found. The initial list should be agreed in writing with GIS. The change management procedure shall govern amendments to the list.

14.53 Statistical techniques

- 14.53.1 Where specific statistical techniques are relevant they shall be indicated in the quality plan.

14.54 Control of packaging and delivery

- 14.54.1 The quality plan shall indicate the control actions to be taken to ascertain the suitability of the packaging and delivery to ensure that the product and spare parts will be delivered to the specified site in a manner that will ensure that the required characteristics are not degraded.

14.55 Product identification and traceability

- 14.55.1 Where traceability is a requirement, the quality plan shall define its scope and extent, including how affected products are to be identified.

14.56 Quality records

- 14.56.1 The quality plan shall indicate how key records specific to the product are to be controlled, including how long they shall be retained and in which language.

14.57 Control of spare parts

- 14.57.1 Where the controls for spare parts vary from those detailed previously, those variations shall be detailed.

15. ACCESS FOR GIS DESIGNATED QUALITY ASSURANCE PERSONNEL

- 15.58 The supplier shall afford access and facilities to the GIS designated quality assurance personnel to visit production lines, quality audit areas, warehouses and other appropriate premises to check that the products or component parts conform to this specification and that the quality plan is being effectively operated.

Note: The quality assurance personnel will be called upon to attend the factory regularly, on a daily basis if necessary, to carry out quality audits on finished products and spare parts, to investigate reported defects and to confirm that the supplier's quality control ensures that the agreed requirements are consistently achieved.

- 15.59 The supplier shall make available, on request, the appropriate quality records, drawings and other control documents.

16. VALIDATION OF INITIAL PRODUCTION

- 16.60 Delivery of a new product shall not be made until a satisfactory examination of initial production has been completed by the GIS designated quality assurance personnel and the supplier has demonstrated the effectiveness of the quality plan.

17. CONCESSION AND PRODUCTION PERMIT PROCEDURE

- 17.61 Application for a concession or a production permit (see note 2) shall be made to the relevant GIS designated quality assurance engineer.

Note 1: All applications shall be confirmed in writing, signed by the supplier's nominated representative. Items may be released only upon communication from the designated quality assurance engineer that the request has been accepted.

Note 2: For the purposes of this section of the specification, the following apply.

Concession: is permission to use or release a limited quantity of material, components or stores already manufactured that do not conform to specified requirements.

Note: 'already manufactured' is to include items partially manufactured.

Production Permit: is permission in advance of or during manufacture, to use materials or make components or stores, which differ from the specified requirements. This permission may operate for a limited quantity or period, and on no account may it be allowed to extend to another contract without further application being made from the supplier.

APPENDIX A REFERENCES

This Specification makes reference to the documents listed below.

A.1 UK LEGISLATION

- LOLER** - Lifting Operations and Lifting Equipment Regulations 1998

A.2 BRITISH STANDARDS

- BS 476-7** - Fire tests on building materials and structures. Method of test to determine the classification of the surface spread of flame of products
- BS 476-12** - Fire tests on building materials and structures. Method of test for ignitability of products by direct flame impingement
- BS 4800** - Schedule for paint colours for building purposes
- BS 6001 Pt 1** - Sampling procedures for inspection by attributes – Part 1: Sampling schemes indexed by acceptance quality limit (AQL) for lot-by-lot inspection
- BS EN 596** - Timber structures. Test methods – Soft body impact test of timber framed walls
- BS EN ISO 9001** - Quality management systems. Requirements
- BS 459** - Specification for matchboarded wooden door leaves for external use.

A.3 IGE STANDARDS

- IGE/GM/8 part 2** - Non domestic meter installations Flow rate exceeding 6 m³ h⁻¹ and inlet pressure not exceeding 38 bar. Part 2: Locations, housing and compounds.

APPENDIX B DEFINITIONS

The definitions applying to this Procedure are given below.

| | | |
|--------------------------------------|---|---|
| Visible or measurable deformation | – | “Visible or measurable deformation” means significant differences in the appearance, shape or strength of the tested sample to that of a comparable and similar untested sample. |
| No visible or measurable deformation | – | No visible or measurable deformation recognisable differences in the appearance, shape or strength of the tested sample to that of a comparable and similar untested sample. |
| Non walk-in | - | A housing for which maintenance is performed externally through the removal of panels or sections, and when the operative does not require access. |
| Walk-in (via one side) | - | A housing for which maintenance is performed through access from one side of the installation only and with access on one side. |
| Walk-in (via two sides) | - | A housing for which maintenance is performed through access from one or both sides of the installation but without direct passage from one side to the other. |
| Walk-in | - | Applies to both “Walk-in (via one side)” and Walk-in (via two sides). |
| Walk-through | - | A housing for which maintenance can be performed through access to all parts of the installation and with direct passage from one side to the other and access doors on both sides. |

APPENDIX C (NORMATIVE) SOAK TEST

C.1 Soak Test

- C.1.1 The specimen panels shall be marked with 16 test points, evenly distributed around the perimeter of the panel, 60mm from the edge.
- C.1.2 The test panel width shall be measured at each of the test points, and then weighed.
- C.1.3 Two specimen panels shall be fully immersed in a vertical plane in clean still water of pH 7 +0.5 at $20 \pm 5^{\circ}\text{C}$ for a period of 14 days. The position of the panels shall allow water access to all surfaces and edges.
- C.1.4 Following immersion for 14 days the measurements taken in clause C.1.2 shall be repeated.

APPENDIX D (NORMATIVE) TEMPERATURE CYCLING TEST

D.1 Temperature Cycling Test

D.1.1 The specimen panels shall be marked with 16 test points, evenly distributed around the perimeter of the panel, 60mm from the edge.

D.1.2 The test panel width shall be measured at each of the test points, and then weighed.

D.1.3 Two specimen panels shall be cycled from ambient temperature to $-20 (+ 2^{\circ}\text{C} - 0^{\circ}\text{C})$ in a period not less than 12 hours. The temperature shall be held at $-20 (+ 2^{\circ}\text{C} - 0^{\circ}\text{C})$ for a period of 12 hours.

The specimen panels shall then be cycled from -20°C to $20 (+ 2^{\circ}\text{C} - 0^{\circ}\text{C})$ in a period not less than 12 hours, and then shall be held at $20^{\circ}\text{C} (+ 2^{\circ}\text{C} - 0^{\circ}\text{C})$ for a period of 12 hours.

The specimen panels shall then be cycled from 20°C to $50^{\circ}\text{C} (+ 2^{\circ}\text{C} - 0^{\circ}\text{C})$ in a period not less than 12 hours, and then shall be held at $50^{\circ}\text{C} (+ 2^{\circ}\text{C} - 0^{\circ}\text{C})$ for a period of 12 hours.

The panels shall then be allowed to cool to ambient temperature.

D.1.4 The temperature cycle in D.1.3 shall be repeated four times.

D.1.5 Following temperature cycling the measurements taken in clause D.1.2 shall be repeated.

APPENDIX E (NORMATIVE) IMPACT TESTS

E.1 Hard Body Impact Test

- E.1.1 A specimen panel shall be freely supported along all four edges in a horizontal plane. The steel impact tool of mass 4.5 kg shall be dropped from a height of 1 metre so that it strikes the centre of the panel.
- E.1.2 Figure 4 shows the impact tool.
- E.1.3 This test shall be repeated with a panel that has undergone and passed the soak test (Appendix C).
- E.1.4 This test shall be repeated with a panel that has undergone and passed the temperature cycling test (Appendix D).

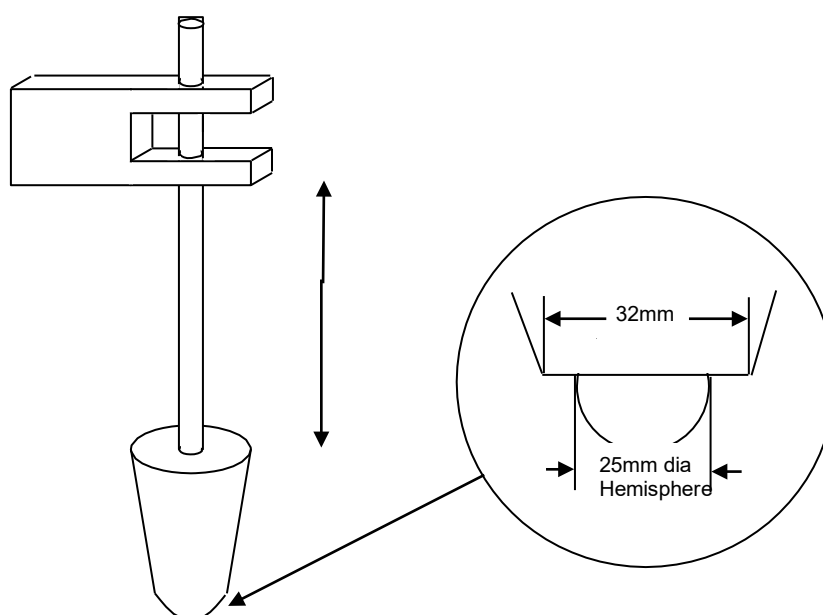

Figure 4. Impact tool

E.2 Soft Body Impact Test

- E.2.1 A specimen wall panel shall be erected vertically and shall be supported in a frame.
- E.2.2 The panel shall be tested using the apparatus and procedures detailed in BS EN 596.
- E.2.3 The point of impact shall be at the centre of the panel.

E.3 Post Fire Test Impact Test

- E.3.1 The specimen panel shall be freely supported along all four edges in a horizontal plane. A steel impact tool of mass 3 kg and surface area of between 5200mm and 10400mm shall be dropped from a height of 1 metre so that it strikes the centre of the burnt area of the panel.
- E.3.2 The test in clause E.3.1 shall be repeated 5 times.

